

» VX3042 «

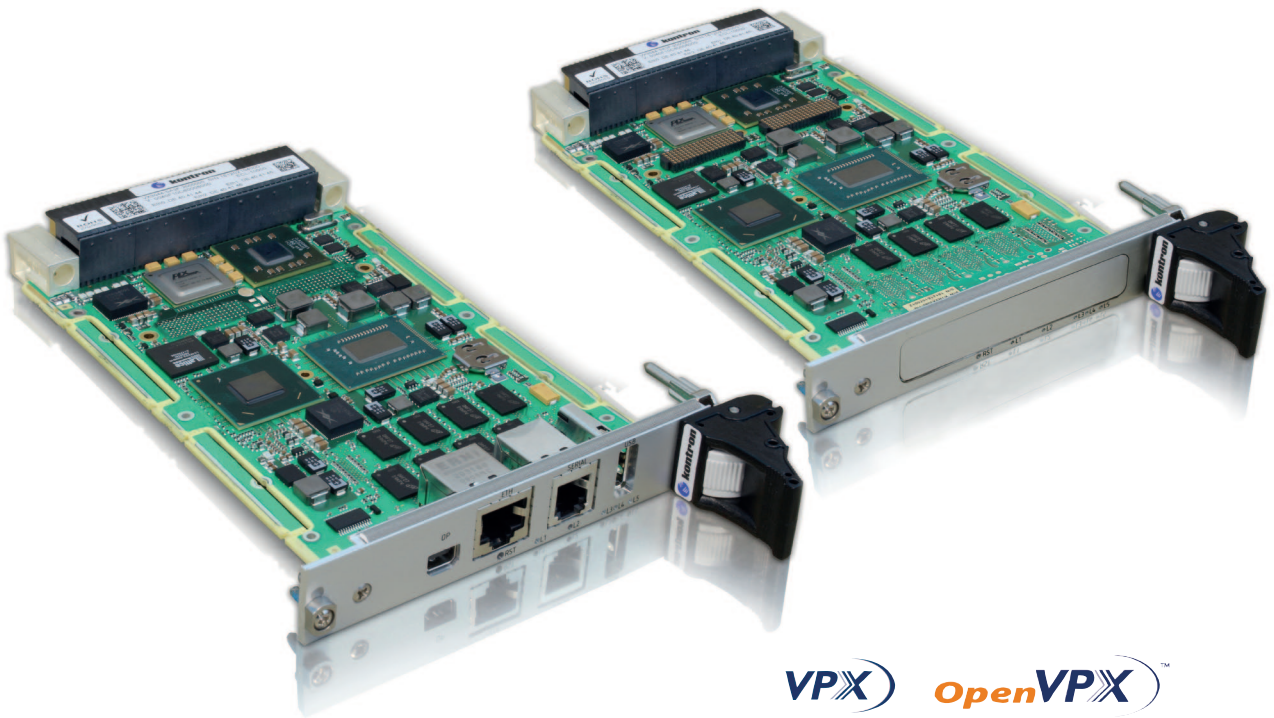

VPX **OpenVPX**

3U VPX 3rd Generation Intel® Core™ i7 based Single Board Computer

- » Intel® Core™ i7 - 3517UE - Dual-Core™ user Configurable TDP
- » Dual Ethernet 10G or 1G
- » PCI Express Gen 3.0, with Kontron VXFabric™
- » XMC with front and rear I/O Support
- » Up to 16 GB SDRAM with ECC and 32GB Soldered SATA NAND Flash

Product Overview

VX3042 is the Kontron 3U VPX rugged Single Board Computer equipped with multiple Ethernet 10G. This SBC implements a new architecture poised to address specific applications and offer the ultimate performance for the Military, Aerospace and Transportation markets.

Based on Intel®'s high performance computing architecture, and supported by Kontron Long Term Supply (LTS) services, VX3042 offers the best feature set.

Target Applications

Console and Rugged Servers

In today's network-centric battlefield, console and high-end servers applications require rugged computers to operate in the most difficult environments. Kontron VX3042 is designed around a high-end Dual Core CPU. This SBC features a configurable TDP, enabling to adjust the board performance to the exact mission profile required. Providing up to 16 GB DDR3-SDRAM, multiple Ethernet 10G and an XMC support, the VX3042 offers numerous configuration variants.

Standards

- » 3U VPX VITA 46, OpenVPX VITA 65, VPX REDI VITA 48
- » Single CPU: compatible with all existing legacy application x86 codes

SWAP-C

- » Four Execution Threads: compact 4-way SMP solution for parallel computing tasks at low power, low size
- » Configurable TDP available on VX3042 board
- » Turbo Boost: overclocked operation of a single-threaded workload in the same power envelope
- » Integrated Graphics Controller with three simultaneous DisplayPorts: for all HMI applications

Safety Critical

- » Two channels of DDR3 soldered memory with ECC: performance and security
- » 1 Mb of permanent Ferroelectric Random Access Memory (F-RAM) allowing permanent retention of application key operational data

- » 8 MB of System Flash with Recovery BIOS Image and permanent storage of BIOS parameters

Connectivity

- » 8 lanes of gen3 PCIe to the backplane: I/O extensions at peak bandwidth. Designed for PCIe Gen3 8GB/s
- » 4 SATA ports to the backplane: for secure RAID storage applications
- » One XMC site with x8 PCIe interface

Versatility

- » VX3042 is available in Standard Air- (SA) and Rugged Conduction-cooled (RC) versions and is compatible with 0.8"(4HP) and 1"(5HP) slot pitch
- » VX3042 with Intel Core i7 3517UE, offers a User Configurable TDP (Thermal Design Point) allowing the user to set up the processor's power and frequency: 25W/2.2 GHz, 17W/1.7 GHz and 14W/0.8 GHz

Compatibility: Certified Solution

VX3042 is compatible with all Kontron VPX building blocks (Payload boards, carriers, switches, backplanes, OS and drivers) and offer backward compatibility with the previous product generations (VX303x SBCs).

Write the code once, run on all the product line. VX3044 is proposed with Kontron VXFabric™ technology which implements TCP/IP protocol over the PCI Express infrastructure.

With 8x PCIe 3.0, running at 8GB/s (theoretical), applications developed previously with VXFabric on VX3030 or VX3035 will enjoy a TCP/IP on PCIe bandwidth exciding 4GB/s (measured) without any code change.

Long Term Supply (LTS)

The VX3042 SBC is part of the Kontron Extended Life Cycle product family, which offers a 15-year life cycle organization on top of Intel® embedded product line silicon life cycle. Available in Kontron 3U VPX development systems, along with 3U VPX carriers and 3U VPX Ethernet plus PCIe switches, the VX3042 is the ideal candidate for long term programs in search of general purpose solutions.

Example of Target Applications

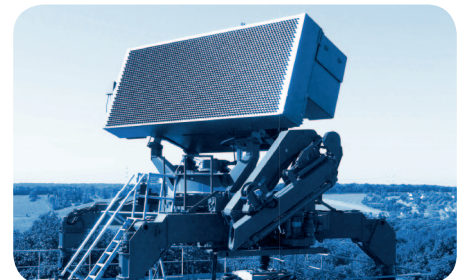

Technical Information

Processor	Third Generation Intel® Core™ i7 processor (22-nanometer silicon technology): » Intel® Core™ i7-3517UE Processor (4M cache, 2 execution cores, 4 threads) » Dual Core, user configurable TDP 25W/2.2 GHz, 17W/1.7 GHz, 14W/0.8 GHz » Integrated Graphics Core, Intel® HD graphics 4000
Onboard Controller	
Platform Controller Hub	Mobile Intel® QM77 Express Chipset: » Up to 6 Gb/s integrated Serial ATA host controllers » USB 2.0 & 3.0 host interface
Graphics	Integrated Graphics Core, Intel® HD graphics 4000 Up to 3 simultaneous graphics heads: » One mini DisplayPort on front panel » Two DisplayPorts available on VPX backplane.
Gigabit Ethernet	» One i82599 10/1 Gigabit Controller connecting two SerDes links (10GBASE-KR or 1000BASE-BX) on VPX backplane » 10GBASE-KR links can be used for backplane board interconnect and/or for SFP+rear cage according SFI specification (redriver recommended) » One i82579 PHY connected on front panel or VPX backplane (user selection) for 1000BASE-T operation
Watchdog	PLD-based, timeout ranging from 2 µs to 510s, IRQ, Reset, dual-stage
System CPLD	One CPLD Board controller for power sequencing, reset handling, monitoring, failure detection, VPX I2C communication. Provides configuration/status registers on LPC interface
RTC	Separated low power RTC with optional onboard battery
SIO	SIO1028 provides two serial lines
Memory	
System Memory	Up to 16 GB dual channel DDR3 SDRAM running at 1333 MHz, with ECC, soldered
Flash (uEFI BIOS)	8 MB FLASH, with recovery image and uEFI BIOS settings
EEPROM	One serial 256 Kbit EEPROM dedicated to system data One serial 256 Kbit EEPROM dedicated to application data
NAND Flash Option	Up to 32 GB SATA Nand Flash storage
Front Interfaces 4HP (0,8") or 5HP (1")	
Graphics	1x mini DisplayPort connector
USB	1x USB 2.0 ports, 4-pin standard USB connectors
Gigabit Ethernet	1x RJ-45 connectors: Ethernet 1000BASE-T Note: This port is configurable from the BIOS to be routed to the VPX P1 connector instead of the front connector
Serial	1x RJ12 connector: EIA-232/EIA-485 UART interface for CPU
LEDs	5 LEDs reporting the board CPU health status and activity
Reset	Reset push button
Onboard Interfaces	
CPU Debug Interface	XDP port for CPU extended debug port connection (only available on a debug connector and need additional test board for XDP access)
XMC Slot	One 8x PCIe to the XMC slot, x8d VITA 46.9 XMC I/O routing, plus 4 single ended pins
VPX Interface	
Slot Profiles	SLT3-PAY-2F2U-14.2.3 SLT3-PAY-1F1F2U-14.2.4 SLT3-PAY-1F1U-14.2.10
Rear I/O via P0/P1/P2	The VX3042 supports: » 1 x8 gen3 PCIe, non transparent capability, on P1 1x1 additional PCIe interface, gen2, on P2 » 2 SATA 3 links on P1 2 additional SATA 2 links on P2 » 2 USB 2.0 and 1 USB 3.0 links on P1 2 additional USB 2.0 links on P2 » 2 SerDes 10GBASE-KR, SFP+/SFI or 1000BASE-BX on P1 » 1 1000BASE-T on P1, optional 2nd 1000BASE-T on P2 » 3 User GPIOs on P1, including OpenVPX GDISCRETE1, and MASKABLE RESET and 3 additional GPIOs on P0 » 2 DisplayPort on P2
Supervisory Functions	» Non Maskable RESET, » NVMRO, SMB 0 and SMB 1 interfaces for Status, Start , Reset. Compatible with Kontron CMB (Monitoring Board), temperature and voltage sensors on the board » PCIe optional use of common reference clock feature
Power Supplies	On P0: VS1=12V, VS3=5V, 3.3V_AUX optional, +12V_AUX and VS2 (3.3V) not connected

Measured Performance

Measured Bandwidth VX3042 & VX3044

5.6 GBytes/sec	PCIe on VPX backplane (DMA raw mode)
3.9 GBytes/sec	TCP/IP on PCIe on VPX backplane (VXFabric™)
1.1 GBytes/sec	10 GETH link on VPX backplane (9.2 Gb/s)

Memory Bandwidth - VX3042

Read	14,7 GBytes/sec
Write	13,8 GBytes/sec

Average Power Consumption

VX3042-SA	34W
Conditions	TDP Nom 17W/1.7 GHz, CPU load = 75%, CPU Temp = 70°C - Turbo Off

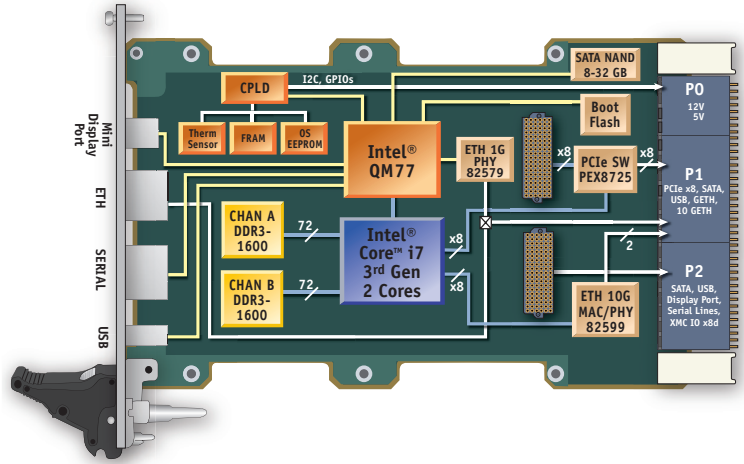

Environmental Specification

	SA - Standard Commercial (1" single height passive module heat sink, forced air)	RA - Rugged Air-Cooled (Optional)	RC - Rugged Conduction-Cooled (Depending on processor frequency)
Conformal Coating	Optional	Standard	Standard
Airflow	26 cfm	TBD	NA
Temperature	VITA 47-Class AC1	VITA 47-Class AC3	VITA 47-Class CC3, CC4 option
Cooling Method	Convection	Convection	Conduction
Operating	0° to +55°C	-40° to +71°C	-40° to +71°C, +85°C option
Storage	-45° to +85°C	-45° to +100°C	-45° to +100°C
Vibration Sine (Operating)	20-500 Hz - 2g	5-2,000 Hz - 3g	20-2,000 Hz - 5g
Random	VITA 47-Class V1	VITA 47-Class V2	VITA 47-Class V3
Shock (Operating)	20g/11 ms Half Sine	40g/11 ms Half Sine	40g/11 ms Half Sine
Altitude (Operating)	-1,640 to 60,000 ft	-1,640 to 60,000ft	-1,640 to 60,000 ft
Relative Humidity	90% without condensation	95% without condensation	95% without condensation

Ordering Information

Article	Order Code	Description
VX3042	VX3042-SA28-2000000	3U Single slot 4 HP (0.8") VPX SBC; Dual Core up to 2.2 GHz Intel® Core™ i7 -3517UE ULV Processor; 8 GB DDR3-SDRAM, 32 GB Sata Flash (MLC) on board, FRAM; I/O: 2x10 GbE, 3xUSB, 4xSATA; Air-Cooled VITA 47 Class AC1 (0°C to +55°C)
VX3042	VX3042-SA24-2010100	3U Single slot 5 HP (1") VPX SBC with onboard XMC slot/no Front Connectors; Dual Core up to 2.2 GHz Intel® Core™ i7 -3517UE ULV Processor; 4 GB DDR3-SDRAM, 32 GB Sata Flash (MLC) on board, FRAM; I/O: 2x10 GbE, 3xUSB, 4xSATA; Air-Cooled VITA 47 Class AC1 (0°C to +55°C)
VX3042	VX3042-SA28-0000000	3U Single slot 4 HP (0.8") VPX SBC; Dual Core up to 2.2 GHz Intel® Core™ i7 -3517UE ULV Processor; 8 GB DDR3-SDRAM, FRAM; I/O: 2x10 GbE, 3xUSB, 4xSATA; Air-Cooled VITA 47 Class AC1 (0°C to +55°C)
VX3042	VX3042-RC24-100N100	3U Single slot VPX SBC with onboard XMC slot; Dual Core up to 2.2 GHz Intel® Core™ i7 -3517UE ULV Processor; 4 GB DDR3-SDRAM, 8 GB Sata Flash (SLC), FRAM; I/O: 2x10 GbE, 3xUSB, 4xSATA; 5 HP (1") if XMC installed, 4 HP (0.8") otherwise; Rugged Conduction-Cooled: VITA 47 Compliant Class CC3 (-40°C to +71°C), Class CC4 (-40°C to +85°C) available upon request, specific conditions may apply, please contact us.
VX3042	VX3042-RC28-300N000	3U Single slot 4 HP (0.8") VPX SBC; Dual Core up to 2.2 GHz Intel® Core™ i7 -3517UE ULV Processor; 8 GB DDR3-SDRAM, 16 GB Sata Flash (SLC), FRAM; I/O: 2x10 GbE, 3xUSB, 4xSATA; Rugged Conduction-Cooled: VITA 47 Compliant, Class CC3 (-40°C to +71°C), Class CC4 (-40°C to +85°C) available upon request, specific conditions may apply, please contact us.

CORPORATE OFFICES

Europe, Middle East & Africa

Oskar-von-Miller-Str. 1
85386 Eching/Munich
Germany

Tel.: +49 8165 77 777
Fax: +49 8165 77 219
info@kontron.com

North America

14118 Stowe Drive
Poway, CA 92064-7147
USA

Tel.: +1 888 294 4558
Fax: +1 858 677 0898
info@us.kontron.com

Asia Pacific

17 Building,Block #1, ABP.
188 Southern West 4th Ring Road
Beijing 100070, P.R.China

Tel.: +86 10 63751188
Fax: +86 10 83682438
info@kontron.cn



Datasheet - VX3042-#06112014MB
 All data is for information purposes only and not guaranteed for legal purposes. Subject to change without notice. Information in this datasheet has been carefully checked and is believed to be accurate; however, no responsibility is assumed for inaccuracies. All brand or product names are trademarks or registered trademarks of their respective owners.